



49" Outdoor Freestanding Digital Posters

# Overview

## Modifications

The screens can be upgraded in various ways including the addition of network features, a camera or more screen sizes.

## Ultra High Brightness Panel

2500cd/m<sup>2</sup> makes sure this display will always be seen whatever the weather. Over 8 times brighter than that of a standard domestic television to improve the displays image clarity.

## Dust Tight

The screen has the highest intrusion protection rating possible meaning it is virtually impossible for dust to enter the enclosure.

## Easy Maintenance

The screen is designed to allow for easy and quick access using hydraulic cylinders when maintenance is required while still being secure.

## Ambient Light Sensor

The display has a light sensor that changes the screens brightness depending on the ambient light ensuring the most suitable brightness at any time.

## Advanced Temperature Control

Designed to run 24/7 in constant use the display has an advanced temperature control system to keep it running at the optimum temperature no matter the environment.

## Toughened Glass

Extra strong glass protects the screens internal components and adds an extra layer of security against vandals.

## Sturdy Enclosure

Made from mild steel the enclosure is strong enough to protect the displays components from outside harm such as vandals.

## Anti Reflective Glass

Diffuses direct sunlight making the display easily readable in bright weather.

## Easy Updates

Update the screen via the simple 'plug and play' USB method. You can control the screen from anywhere in the world by upgrading to a Network version. This allows you to update the screen via the cloud.

## Attach Devices

Run the screen from the integrated Media Player or attach your own device either in the screens small internal locker.

## Removable Base

If desired the base can be removed before installation for a more streamline appearance.

## Weather Proof

An IP65 Rating means the display is able to withstand all weather conditions; wet and dry and also features waterproof over molded AV connectors.

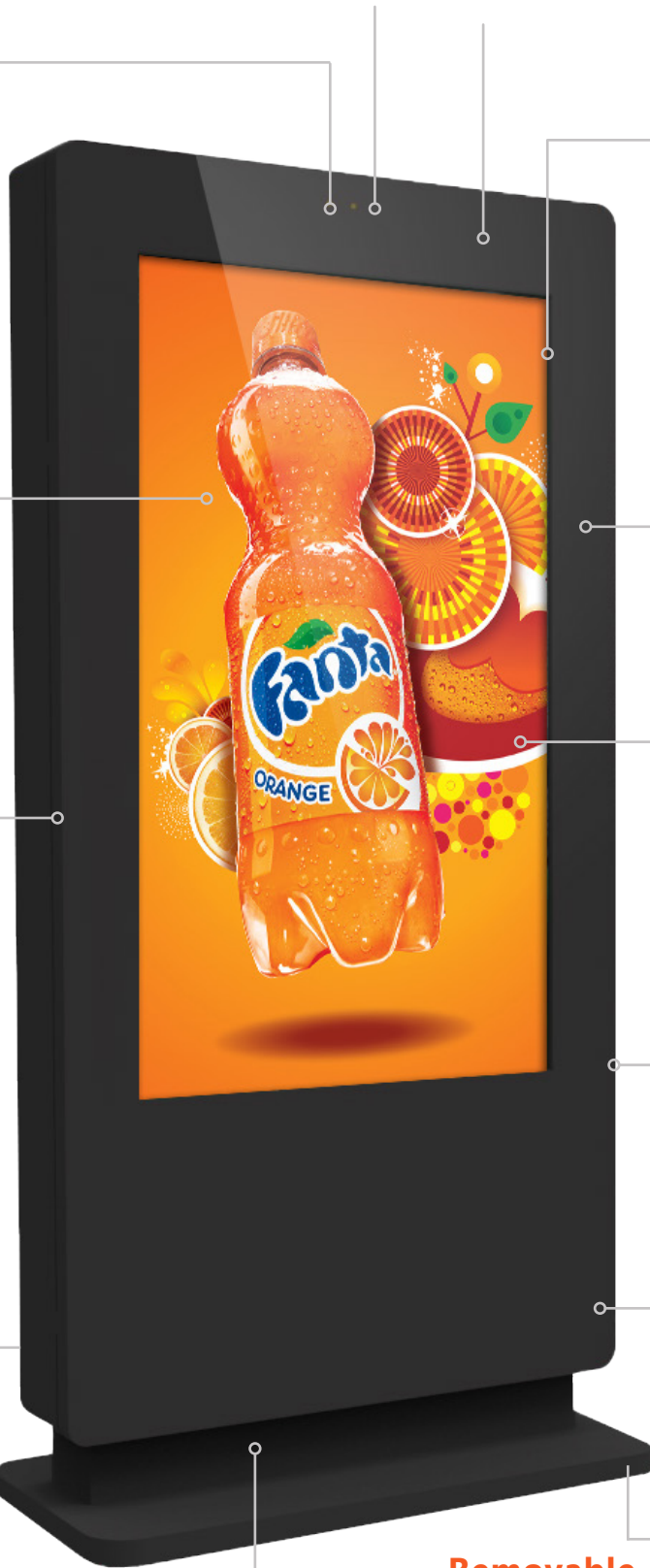
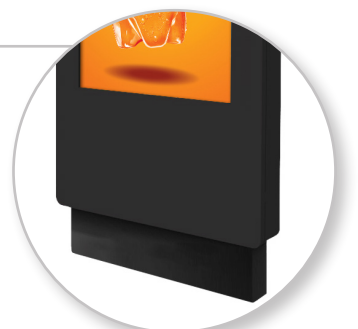



## Sunlight Readable

Brightness is paramount when using outdoor screens, these displays use commercial grade Ultra High Brightness panels (2500 cd/m<sup>2</sup>); more than 5 times brighter than a standard home TV to allow easy readability in direct sunlight. The display also has an ambient light sensor that will alter the screens brightness based on the displays surrounding light levels. This leaves the screen with the best clarity while also conserving energy.



## Outdoor Enclosure

Designed with robust, corrosion protected, casing to protect against the elements and the public. With an IP65 rating, it keeps out all airborne particles as well as being protected from any wet weather conditions and also feature waterproof over molded AV connectors. The enclosures are made from mild steel and have thermally toughened glass.



## Temperature Control

The internal air-conditioning system allows the screens to be in constant use in an outdoor environment. Internal fans keep the panel and other internal components at the optimum working temperature; ensuring a long and reliable life for your display.

## Features

### 24/7 Usage



Built with commercial grade panel and components these displays are designed to run 24/7 in constant use; unlike domestic screens. The panel also has a lifespan of over 50,000 hours of continuous use.

### Anti Reflective Glass

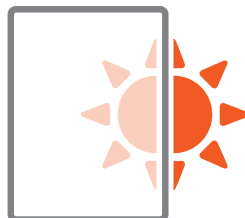

The glass frontage is also anti-reflective to help defuse direct sunlight shining on the display.

## Easy Installation & Maintenance



These units are designed with installation and maintenance in mind. As well as having a cabling channel built into the base of the unit there are also special fitting holes to allow you to permanently fix your screen in position. There is also internal space within the unit to hide any additional hardware, such as a PC, with easy access in the form of a front panel door.

## Modifications Available



Whether your project calls for a touch screen, a double-sided display or even a bespoke screen size, we can meet your needs.

## Integrated Media Player



As well as having AV inputs, these displays also have a built-in HD media player allowing you to run content copied from a USB drive. Load your pictures and videos onto a USB memory stick then insert it into the display, the screen will then start playing the pictures and videos in a continuous loop. The displays can also be upgraded to be updated remotely via a cloud-based CMS.



		49" Outdoor Freestanding Digital Posters	
<b>Panel</b>	Display Size	49 Inch	
	Resolution	1080x1920	
	Pixel Pitch	0.5592 x 0.5592	
	Display Area (mm)	603x1073	
	Aspect Ratio	16:9	
	Brightness (cd/m2)	2500	
	Colour	1.06 Billion	
	Viewing Angle	178°	
	Contrast Ratio	8000:1	
<b>AV Inputs</b>	Video	HDMI, VGA	
<b>Power</b>	Power Consumption (W)	530	
	Input Voltage	AC110~240V (50Hz~60Hz)	
<b>Mechanical</b>	Unit Size (WxHxD mm)	870x1940x180	
	Net Weight (kg)	120	
<b>Environmental</b>	Operating Temperature:	-20 °C to 50 °C	
	Operating Humidity:	10% - 80%	
	Storage Temperature:	-30°C - 60°C	
	Storage Humidity:	5% - 90%	
	Enclosure Protection	IP65	
<b>Feature</b>	Internal Media Player	Media Formats	Video (MPG, AVI, MP4, RM, RMVB, TS), Audio (MP3, WMA), Image (JPG, GIF, BMP, PNG)
		Media Resolution	1080x1920
		Internal Memory	6GB
		CPU	Duel-Core Cortex-A9 @1.6GHz
		GPU	Mali-400 MP4 @400MHz
		RAM	1GB DDR3
		ROM	8GB NAND
		USB	USB2.0 HOST (x2)
		LAN	10/100M Ethernet (Network version screen only)
		Wi-Fi	802.11b/g/n (Network version screen only)
		OS	Android 4.2.2
		Graphic Engine	OpenGL ES 1.1/2.0, OpenVG 1.1
	Special	Images, Videos, Audio, Scrolling Text Message, On/Off Timer, On Screen Clock, Media Rotation	
<b>Accessories</b>	Included	AC Power Cable, Remote Control	
	Optional	Touch Screen Upgrade, Network Upgrade, Camera	

**Technical Drawing:**

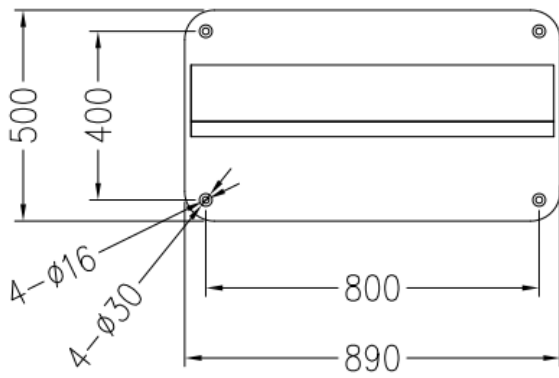
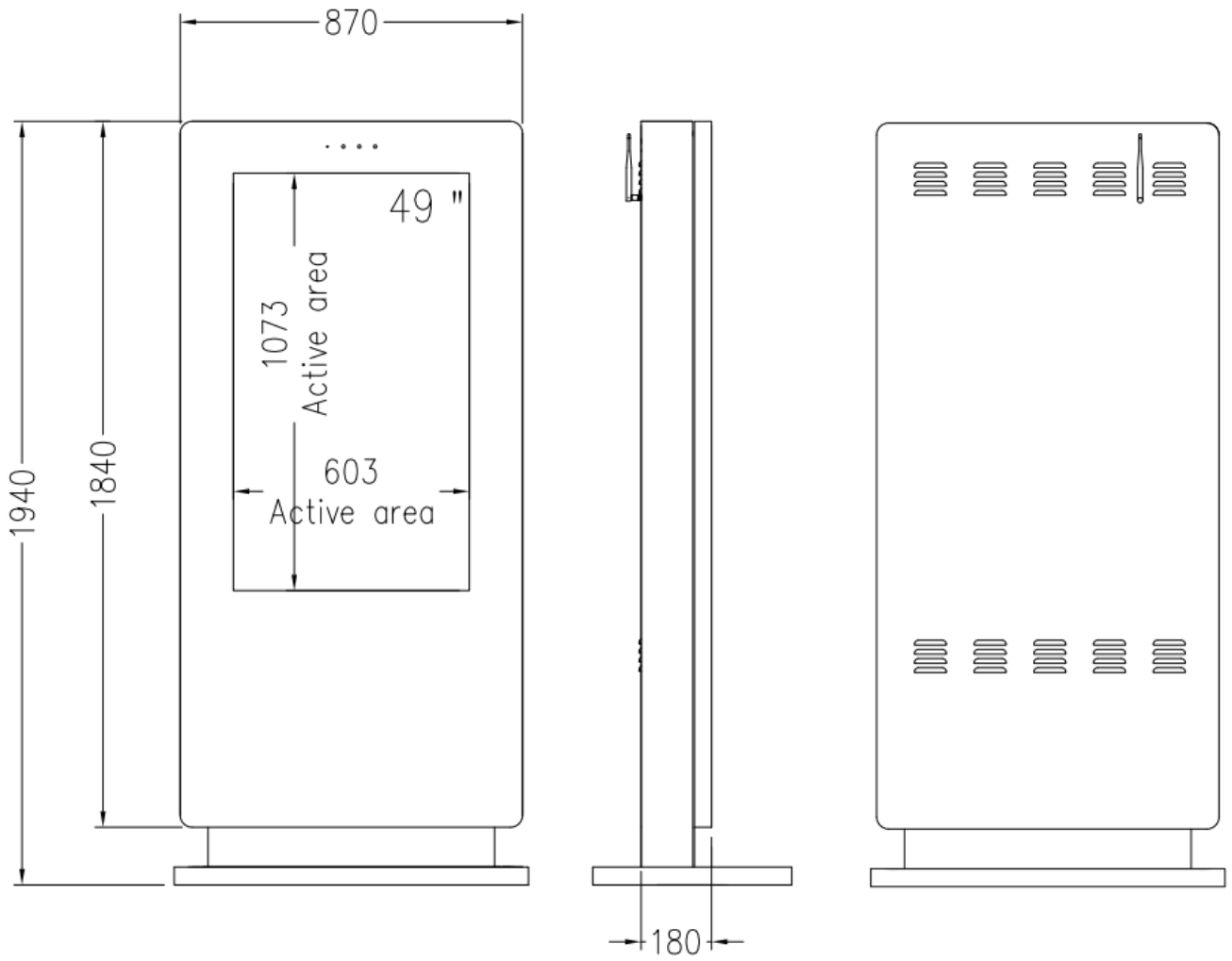

**Note:** The  $\phi 30$  holes are for access, we recommend using M10 anchor bolts that will fit into the  $\phi 16$  holes.